

UWB-WiMedia Signal Generation Using Advanced Waveform Editing Tools

Application Note

As new applications utilize wireless transmission and digital RF systems proliferate, engineers need better ways to create intricate RF signal behaviors and interactions. This application note discusses the challenges of generating frequency hopping Ultra-Wideband (UWB) signals and the various options that RF design engineers have when creating UWB-WiMedia signals using an Arbitrary Waveform Generator (AWG). Although UWB promises high data rates, it is also highly complex to create these signals in the lab and to preserve signal integrity.

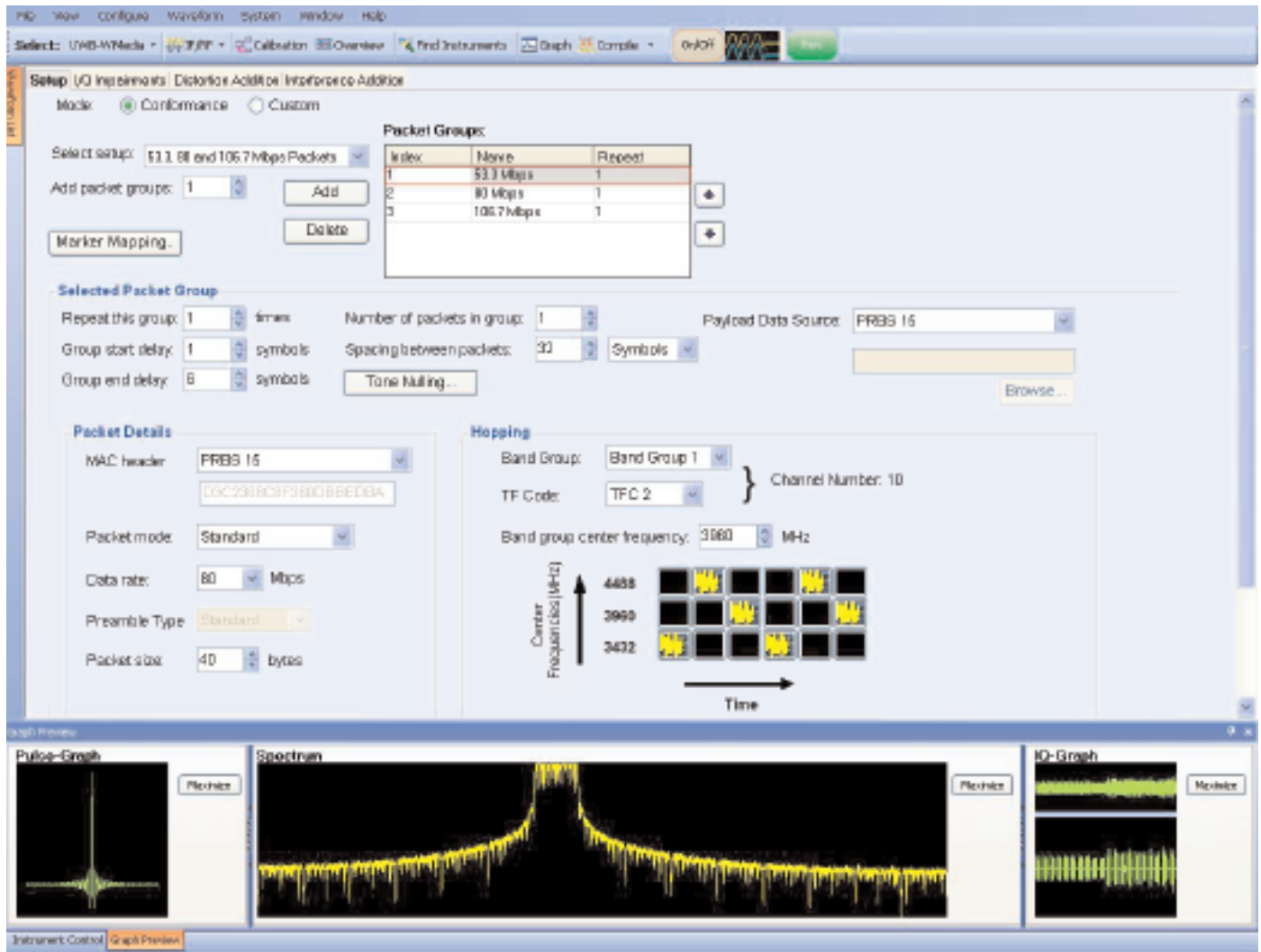

Figure 1. RFXpress in conformance mode. RFXpress is a software package to synthesize digitally modulated baseband. IF and RF signals which can be generated with Tektronix AWG7000 Series arbitrary waveform generators (AWGs).

As RF signals are becoming more and more complex, it is necessary to utilize tools that enable RF designers to accurately synthesize these signals. Such tools need to help designers create signals up to 9.6 GHz for all WiMedia band groups in a single instrument with ease, and take advantage of the wideband signal generation capabilities of modern AWGs. Designers also need the capability to define the amplitude of the signals in either volts or dBm. Figure 1 is an example of such a software tool, RFXpress.

To provide high data rates, the FCC in 2002 approved the unlicensed use of UWB devices in the spectrum of 3.1GHz to 10.6GHz for short range communication. The term UWB is used to describe when the bandwidth of the signal is greater than 20% of the carrier frequency. That is Fractional bandwidth = $(f_H - f_L)/f_c > 20\%$ or total BW > 500MHz.

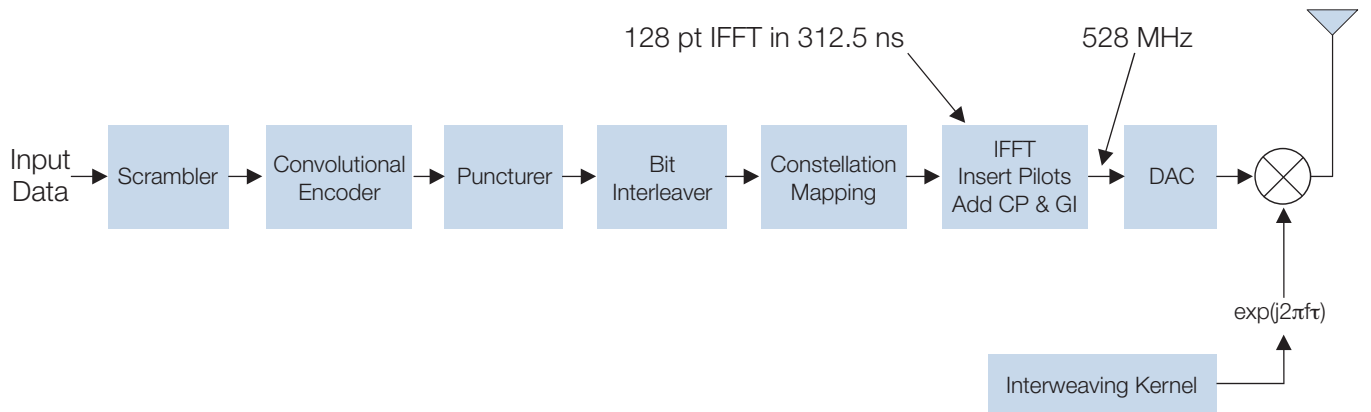

Figure 2. UWB WiMedia Tx chain.

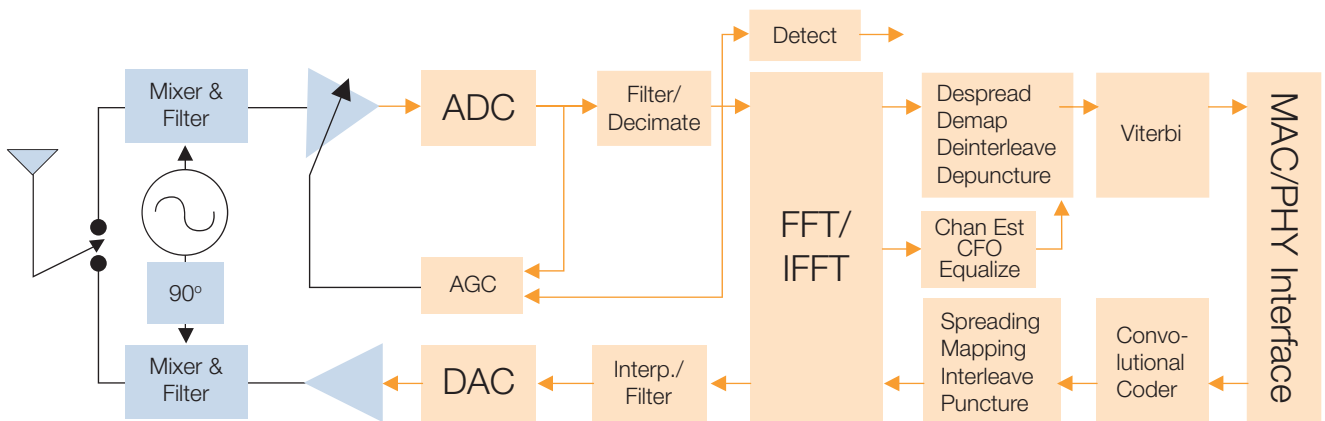

Figure 3. Block diagram of a UWB Tx / Rx.

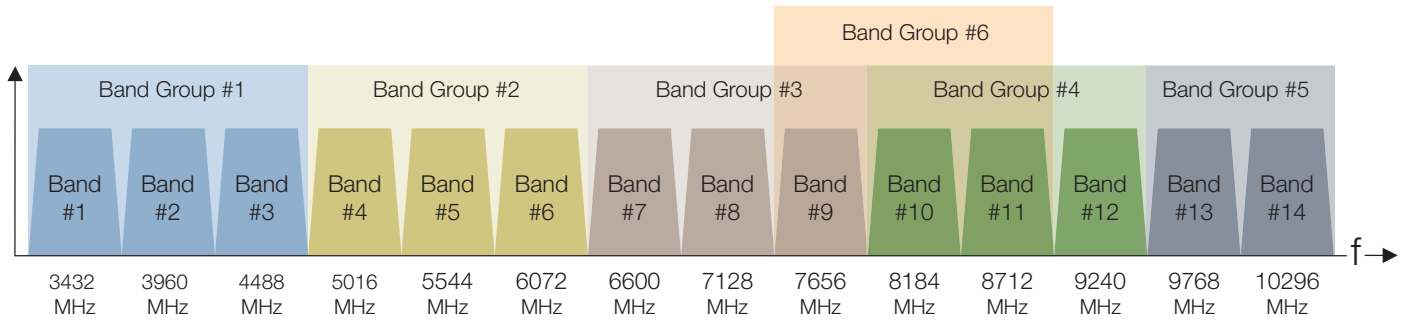

Figure 4. WiMedia band groups.

Band Group	Band_ID (n_b)	Lower Frequency (MHz)	Center Frequency (MHz)	Upper Frequency (MHz)
1	1	3168	3432	3696
	2	3696	3960	4224
	3	4224	4488	4752
2	4	4752	5016	5280
	5	5280	5544	5808
	6	5808	6072	6336
3	7	6336	6600	6864
	8	6864	7128	7392
	9	7392	7656	7920
4	10	7920	8184	8448
	11	8448	8712	8976
	12	8976	9240	9504
5	13	9504	9768	10032
	14	10032	10296	10560
6	9	7392	7656	7920
	10	7920	8184	8448
	11	8448	8712	8976

Figure 5. WiMedia band groups allocation table.

One approach to this is UWB-WiMedia which uses a multiband OFDM technique. As shown in Figure 4, the WiMedia specification divides the UWB frequency spectrum into six band groups: the first four band groups consist of three bands, the fifth band group consists of two bands and the sixth band group lies within the spectrum of the first four band groups.

Each of the bands has a bandwidth of 528MHz. The physical layer uses OFDM technology with 122 tones in each of the 528MHz bands. The OFDM packets are then spread using a Time-Frequency Code (TFC). Two types of spreading are defined: one uses frequency hopping over the three bands and is referred to as Time-Frequency Interleaving (TFI), and the other is transmitted in a single band and is referred to as Fixed Frequency Interleaving (FFI).

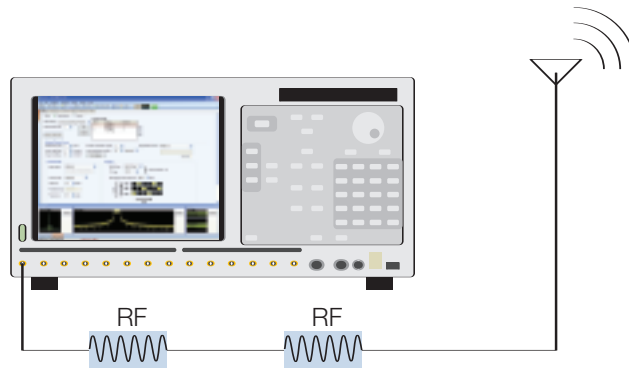

Figure 6. WiMedia direct RF signal generation using an AWG and RFXpress software. External PC not required.

Parameter	Description	Value
f_s	Sampling frequency	528 MHz
N_{FFT}	Total number of subcarriers (FFT size)	128
N_D	Number of data subcarriers	100
N_P	Number of pilot subcarriers	12
N_G	Number of guard subcarriers	10
N_T	Total number of subcarriers used	122 (= $N_D + N_P + N_G$)
D_f	Subcarrier frequency spacing	4,125 MHz (= f_s / N_{FFT})
T_{FFT}	IFFT and FFT period	242,42 ns (Δf^{-1})
N_{ZPS}	Number of samples in zero-padded suffix	37
T_{ZPS}	Zero-padded suffix duration in time	70,08 ns (= N_{ZPS} / f_s)
T_{SYM}	Symbol interval	312,5 ns (= $T_{FFT} + T_{ZPS}$)
F_{SYM}	Symbol rate	3,2 MHz (= T_{SYM}^{-1})
N_{SYM}	Total number of samples per symbol	165 (= $N_{FFT} + N_{ZPS}$)

Figure 7. Timing related parameters.

Direct RF Synthesis

Direct synthesis is a sampling-based technology. Whereas an oscilloscope acquires sample points from analog waveforms, a direct synthesis signal source—also known as an Arbitrary Waveform Generator (AWG) creates analog waveforms from sample points. The sample points in an AWG's memory can define essentially any waveform.

Figure 6 shows the arrangement of a single-channel AWG that generates the UWB signal directly at the final frequency. The speed and the analog bandwidth requirements for the AWG depend mainly on the specific band groups to be covered and not on the hopping nature of the final signal.

Band Group #1 (maximum frequency 4,752MHz), requires a minimum sampling rate of 10GS/s and analog bandwidth of 5GHz. Band Group #2 requires 15GS/s sampling speed and 6.5 GHz analog bandwidth. Figure 7 shows the timing related parameters that are specified in the WiMedia standard.

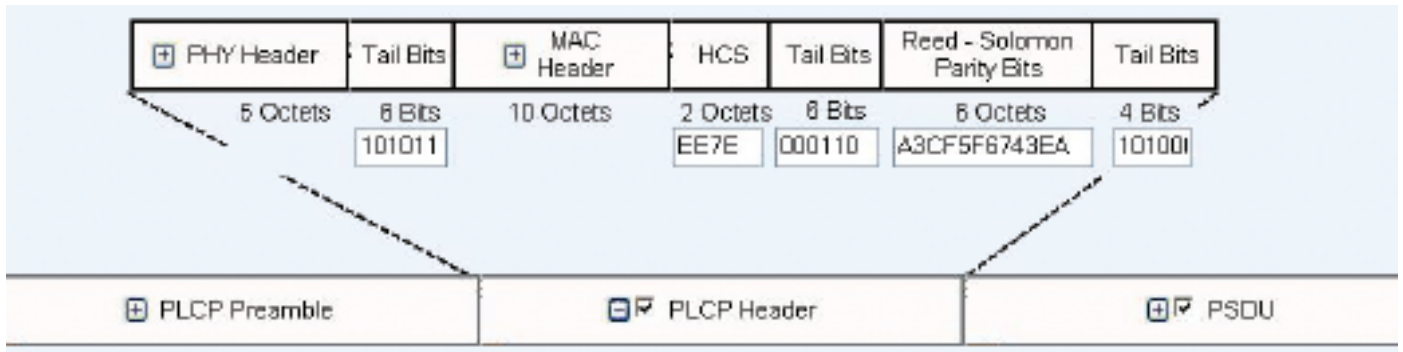

Figure 8. PDU structure.

State-of-the-art AWG instruments from Tektronix are capable of generating 9.6 GHz bandwidth waveforms at 24GS/s, so it is possible to generate all Band Groups including hopping with ease and with one single instrument. Direct RF Synthesis requirements for calibration are low. Controlled thermal behavior, low drift in time, and the lack of external equipment allow for factory calibration while keeping an acceptable signal quality over a long period of time.

The next sections will discuss the use of RF/IF/IQ Waveform Creation and Editing Tools, specifically Tektronix RFXpress software, to generate UWB-WiMedia Signals.

PPDU Structure

Figure 8 shows the format of PLCP Protocol Data Unit (PPDU), which is composed of three major components:

- PLCP Preamble (Physical Layer Convergence Protocol)
- PLCP Header
- PSDU - PHY Service Data Unit

They are transmitted in the same order as stated above.

PLCP Preamble

The PLCP preamble is the first component of the PPDU and can be further decomposed into a packet/frame synchronization sequence and a channel estimation sequence. The goal of the PLCP preamble is to aid the receiver in timing synchronization, carrier-offset recovery and channel estimation.

The Preamble is defined to be a real baseband signal. For the lowest data rate modes (53.3Mb/s and 80Mb/s), the data type of the preamble is the same as the payload, that is, both signals are real. For the higher data rates, the preamble is inserted into the real portion of the complex base band signal.

Two preambles are defined: a standard PLCP preamble and a burst PLCP preamble. The burst preamble is only used in the streaming mode when a burst of packets is transmitted, separated by a minimum inter-frame separation time (pMIFS).

RFExpress allows the changing of all of these for testing the receiver. For example, in custom mode one can edit the Base time-domain sequence and test the receiver for any corrupted preamble sequence.

PLCP Header

The PLCP header is the second major component of the PPDU. The goal of this component is to convey necessary information about both the PHY and the MAC to aid in decoding the PSDU at the receiver. The PLCP header can be

further decomposed into a PHY header, MAC header, header check sequence (HCS), tail bits and Reed-Solomon parity bits, as well as tail bits at the end of the PLCP header to return the convolutional encoder to the zero state. The Reed-Solomon parity bits are added to improve the robustness of the PLCP header. Figure 9 shows the WiMedia frame related parameters as specified in the standard.

The PHY header field is composed of 40 bits, numbered from 0 to 39.

- Bits 3-7 encode the RATE field, which conveys the information about the type of modulation, the coding rate and the spreading factor used to transmit the MAC frame body.
- Bits 8-19 encode the Length field, with LSB being transmitted first.
- Bits 22-23 encode the seed value for the initial state of the scrambler, which is used to synchronize the descrambler of the receiver.
- Bit 26 encodes whether or not the packet is being transmitted in the burst mode.
- Bit 27 encodes the preamble type used in the next packet if in burst mode.
- Bits 28-30 are used to indicate the TF code used at the transmitter.
- Bit 31 is used to indicate the LSB of the band group used at the transmitter.
- All other bits which are not defined are reserved for future use and set to zero.

Parameter	Description	Value
N_{pf}	Number of symbols in the packet/frame synchronization sequence	Standard Preamble: 24 Burst Preamble: 12
T_{pf}	Duration of the packet/frame synchronization sequence	Standard Preamble: 7,5 μ s Burst Preamble: 3,75 μ s
N_{ce}	Number of symbols in the channel estimation sequence	6
T_{ce}	Duration of the channel estimation sequence	1,875 μ s
N_{sync}	Number of symbols in the PLCP preamble	Standard Preamble: 30 Burst Preamble: 18
T_{sync}	Duration is the PLCP preamble	Standard Preamble: 9,375 μ s Burst Preamble: 5,625 μ s
N_{hdr}	Number of symbols in the PLCP header	12
T_{hdr}	Duration is the PLCP header	3,75 μ s
N_{frame}	Number of symbols in the PSDU	$6 \times \left[\frac{8 \times \text{LENGTH} + 38}{N_{IBP6S}} \right]$
T_{frame}	Duration for the PSDU	$6 \times \left[\frac{8 \times \text{LENGTH} + 38}{N_{IBP6S}} \right] \times T_{SYM}$
N_{packet}	Total number of symbols in the packet	$N_{sync} + N_{hdr} + N_{frame}$
T_{packet}	Duration of the packet	$(N_{sync} + N_{hdr} + N_{frame}) \times T_{SYM}$

Figure 9. Frame related parameters.

PSDU

The PSDU is the last major component of PPDU. This major component is formed by concatenating the frame payload with the frame check sequence (FCS), tail bits and the pad bits, which are inserted to align the data stream on the boundary of the symbol interleaver.

RFXpress allow for not only generating signals in the WiMedia conformance mode, but also to customize the frame generation for all parts of the frame. This enables the characterization of the receiver beyond the boundary conditions set by the WiMedia protocol.

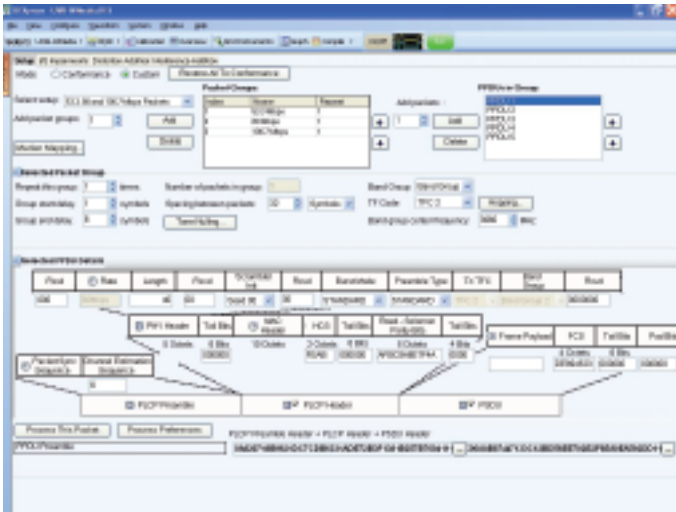

Figure 10. RFXpress in custom mode.

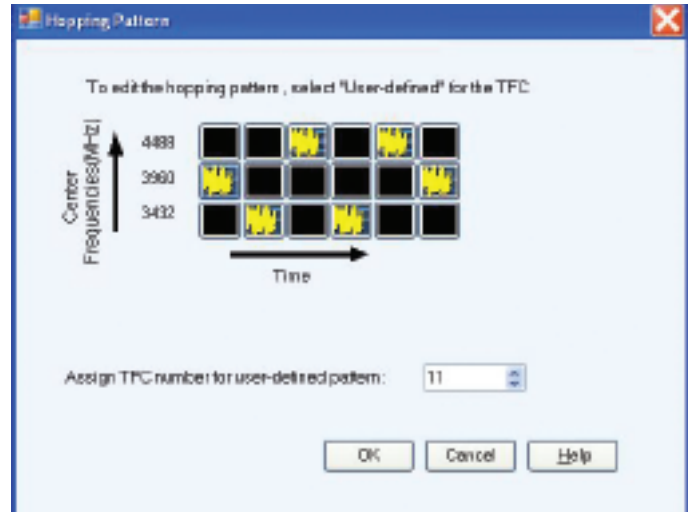

Figure 11. User defined TFC in RFXpress custom mode.

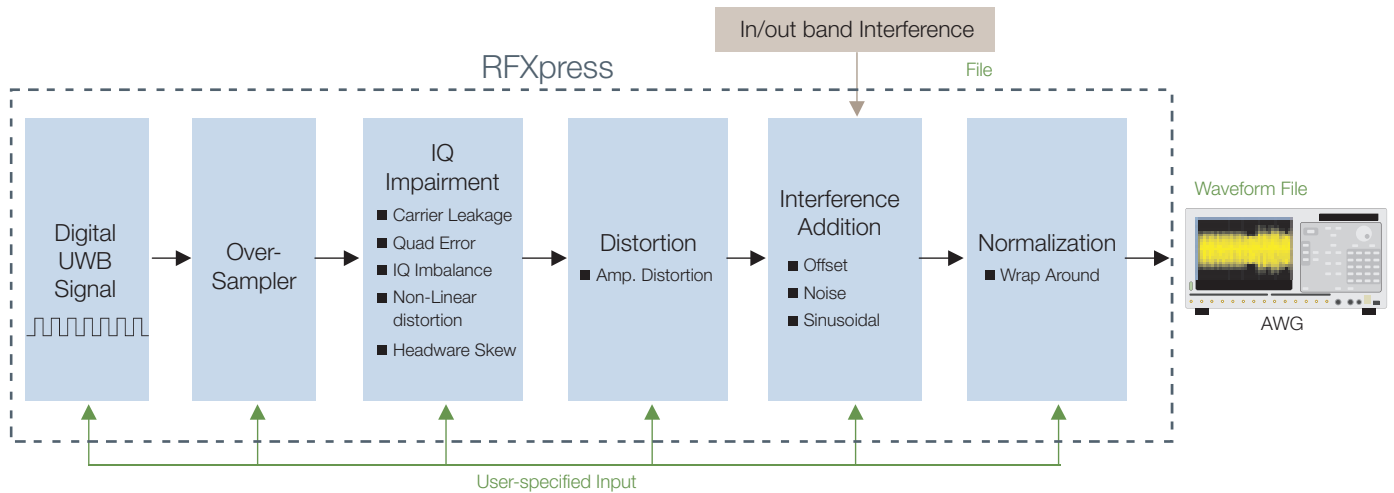

Figure 12. RFXpress signal flow chart.

In RFXpress custom mode as shown in Figure 10, PPDU can be generated with PLCP preamble, PLCP header and PSDU. To test a part of the receiver, the situation might demand that only parts of PPDU be generated. RFXpress enables the generation of only PLCP preamble, only PLCP preamble and PLCP header, or only PLCP preamble and PSDU. PPDU with the same characteristics can be grouped together to form packet groups. The number of packets within the packet group can be defined. Spacing between the packets can be specified in symbols, pMIFS or in pSIFS.

Define Your Own TFC

It is not uncommon that one may want to test the receiver with a non-standard TFC pattern. As shown in Figure 11, RFXpress permits configuring a custom hopping pattern and saving it as a user-defined TFC pattern to be recalled later. Figure 12 shows the RFXpress signal flow chart.

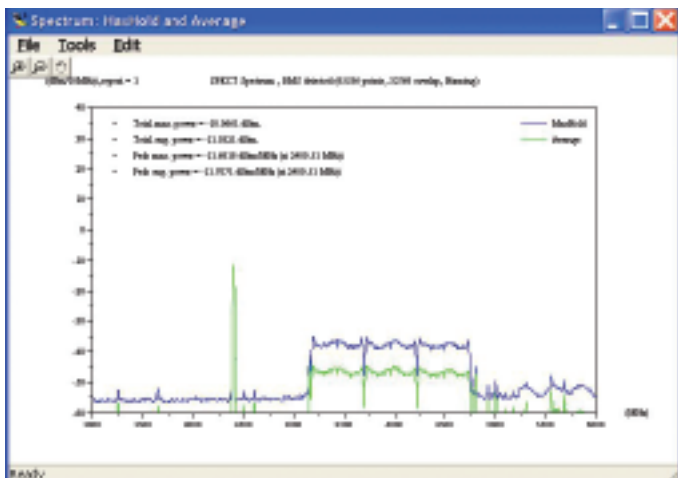

Figure 13. Out-of-band interferer.

Signal Under Your Control

All kinds of IQ impairments including carrier leakage, quadrature error, and IQ imbalance can be added to the IQ baseband signal. If using an IQ modulator for up-converting to higher bands, the signals can be thoroughly stressed to test the performance margins of the receiver.

Also it is important that the receiver is tested in all real world scenarios. For example, you can apply ready-to-use “real world interfaces” like WiFi (802.11a and MIMO), WiMax, Radar, and captured baseband waveforms or interferer to the WiMedia waveform in RFXpress. Figure 13 shows a 2.4GHz CW tone being added as an interferer.

Connect, Capture, Replay

Most of the modern communication devices are transceivers and therefore it is very important that the receiver is tested with real life signals. In today’s world where research and development needs to be coordinated between multiple locations, it is important that the same signals are reproduced in all locations in the same way to characterize or to test the particular behavior of the DUT.

The signals captured in one location from an oscilloscope can be sent to another location for replay. The other location just needs to recall the AWG setup files to get the same kind of signal behavior as observed in the first location.

This enables an unprecedented way of reproducing signals at any site with the same level of accuracy and precision, making it easy for designers to overcome challenges in the design cycle.

Tone Nulling

For UWB-WiMedia, a mechanism is defined to avoid interference when UWB signals coexist with other transmitters, such as radios and radars. Once detected, the detect and avoid, or DAA, operation allows specific OFDM tones to be nulled during transmission. It is often desired to see the impact this might have on a receiver.

The most common technique for creating a notch in the frequency domain is to zero out tones that overlap with the radio astronomy band. The advantage of this technique is that there is no increase in complexity of the transmitter. The transmitted OFDM signal is constructed using an Inverse Discrete Fourier Transform (IDFT). As a rectangular window is applied to the data, each tone has a wider than expected spectrum, where the spectrum has the shape of a sinc function. Although the sinc function has zero crossings at each of the tone locations, zeroing out only a few tones results in a shallow notch. For example, to obtain a notch with a depth of 23 dB for the radio astronomy band, a total of 29 tones needs to be zeroed out. This corresponds to a total loss of 120MHz of bandwidth.

RFXpress not only allows the nulling of tones, but also allows the ability to have intermediate values for both amplitude and phase as shown in Figure15. This enables the simulation of a real world scenario with the sub-carrier amplitudes at various levels for testing receivers.

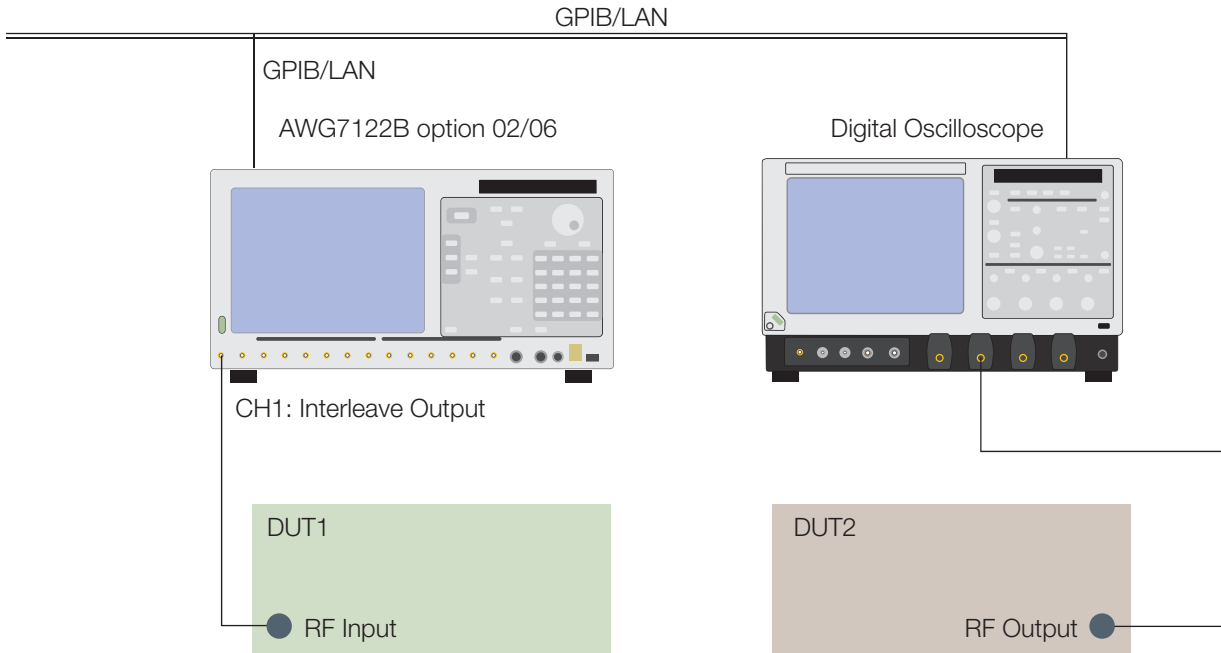

Figure 14. Connect, capture and reply a waveform from an oscilloscope.

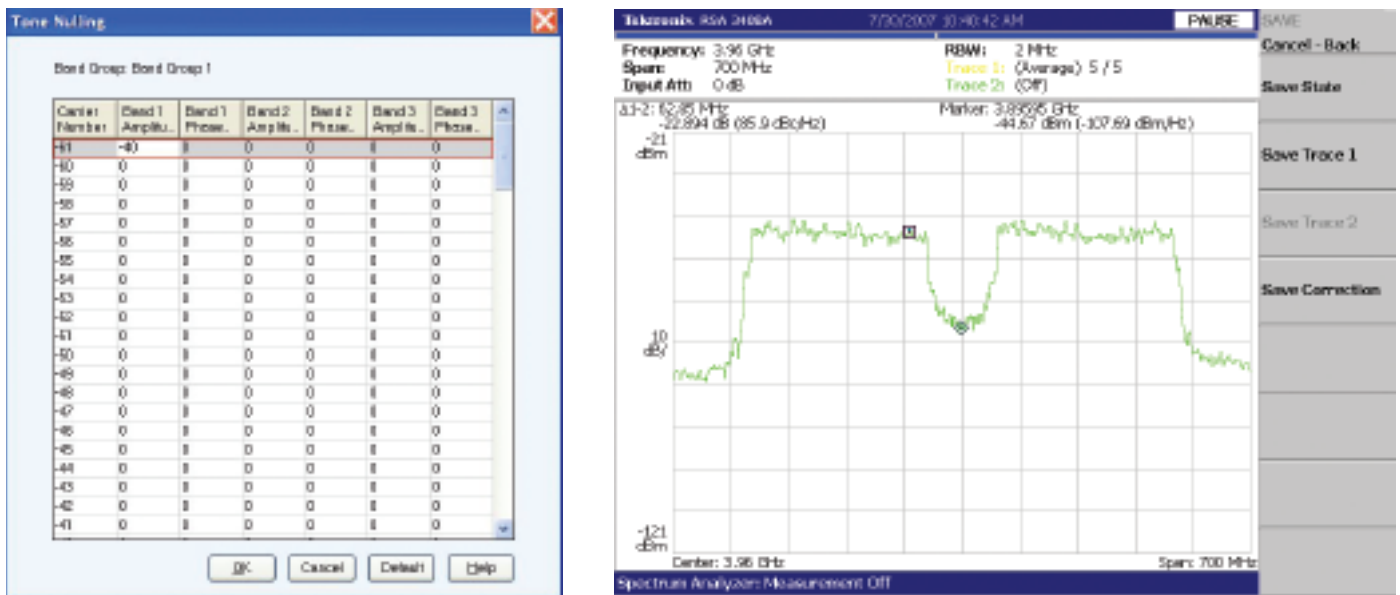

Figure 15. Tone nulling.

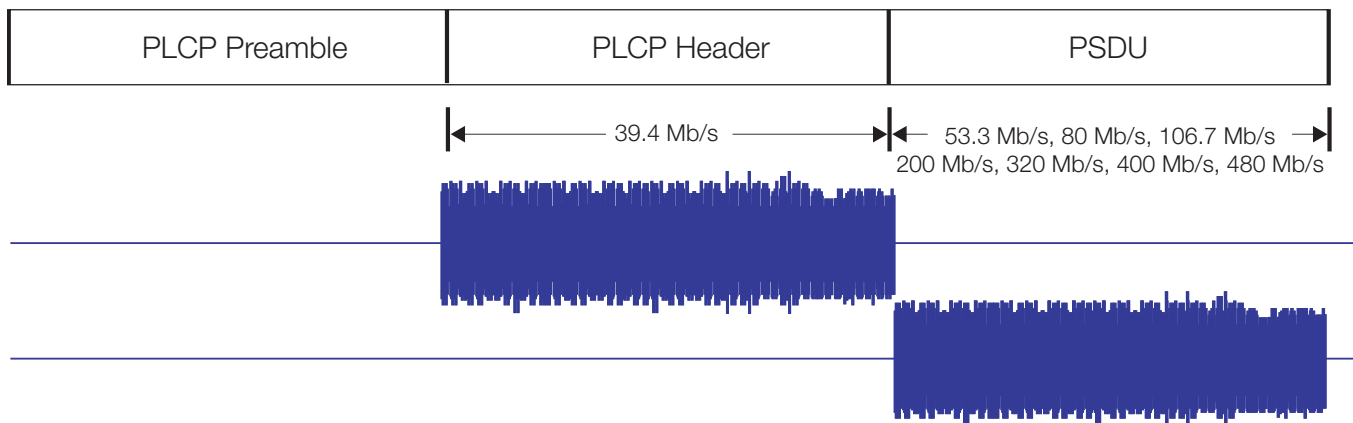
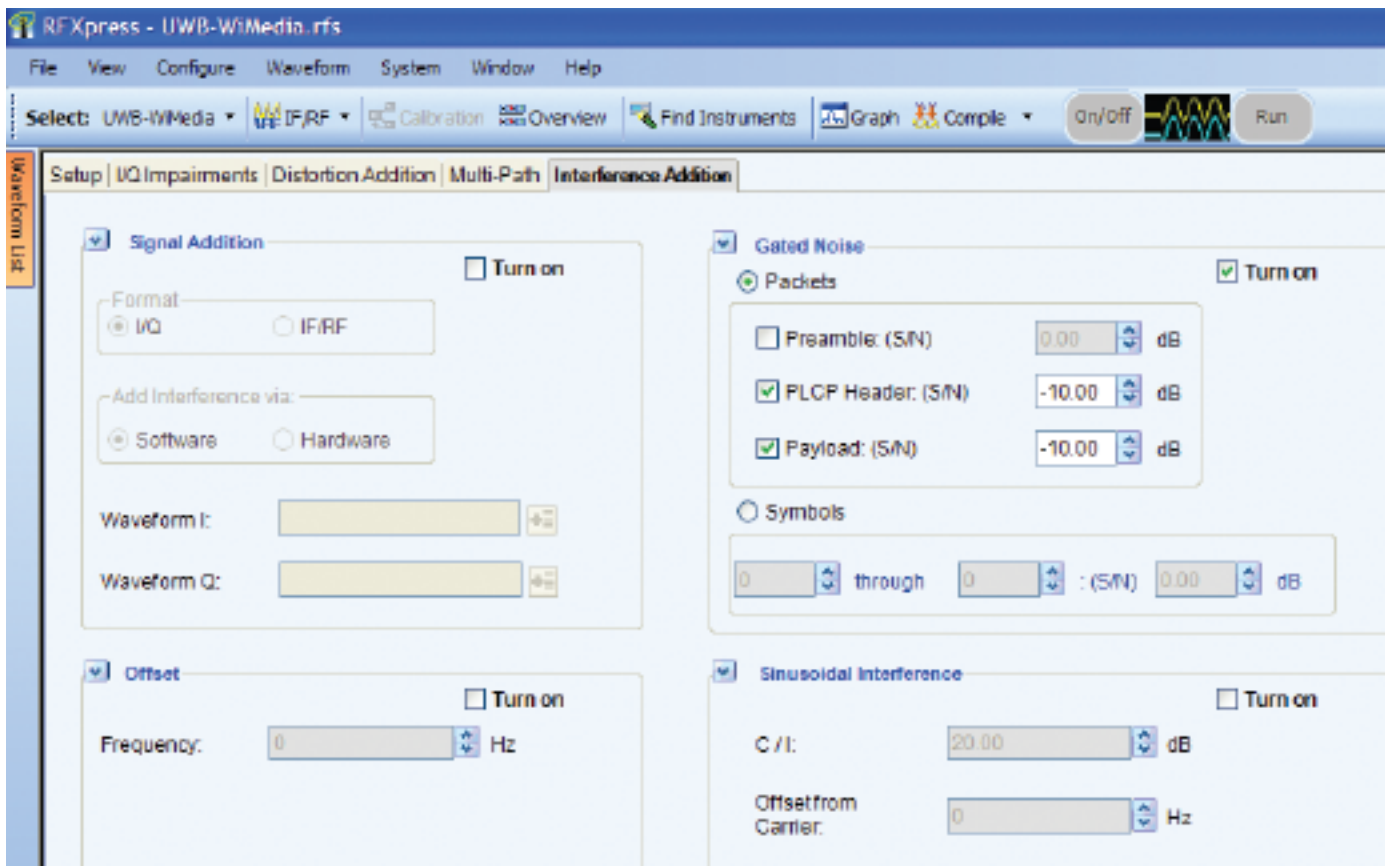

Figure 16. Symbolic representation of gated noise.

Gated Noise

It is not uncommon that only parts of the packet get corrupted during transmission. RFXpress has the functionality to add noise with desired intensity to a particular portion of

the PPDU structure. For example, noise can be added only to the PLCP header and Payload as shown in Figure 16. Noise also could be applied only to a specific number of symbols in a packet.

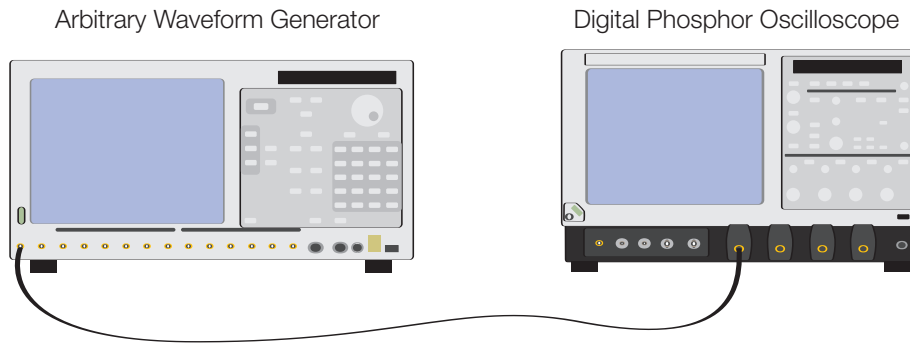

Figure 17. Generation and analysis solutions working together.

Analysis of the Results

The WiMedia system is capable of transmitting information at data rates 53.3, 80, 106.7, 160, 200, 320, 400 and 480 Mb/s. Digitally synthesized signals using RFXpress can be verified using Tektronix WiMedia software. The Tektronix AWG7122B arbitrary waveform generator with option 6 high bandwidth output 24GS/s interleaved can be used

to generate all UWB-WiMedia Band Groups (BG1 - BG6)** RF signals. The WiMedia Analysis portion of the software includes real time spectrograms and spectrum plots for bandwidth and down-converted Spectrograms, as well as spectrum plots to user adjustable frequency bands. The WiMedia analysis software section also down-converts to WiMedia band groups to determine TFC (hopping sequences), and mask tests Power Spectral Density and channel power in these bands.

Summary

This application note has outlined the steps, using an advanced RF/IF/IQ waveform creation and editing tool, to easily generate UWB signals. With RF signals increasing in complexity, it is becoming more essential to utilize tools that help RF designers correctly synthesize these signals. Such tools enable design engineers to easily create signals with over 9.6 GHz bandwidth in a single arbitrary waveform generator. With the increase of new applications that utilize wireless transmission and digital RF systems, engineers need faster and easier ways to create intricate RF signal behaviors and interactions. There are now new choices for generating frequency hopping Ultra-Wideband (UWB) signals.

Abbreviation and Acronyms

BER	Bit Error Rate	PHY-SAP	Physical Layer Service Access Point
BM	Burst Mode	PLCP	Physical Layer Convergence Protocol
CCA	Clear Channel Assessment	PLME	Physical Layer Management Entity
CRC	Cyclic Redundancy Code	PMD	Physical Medium Dependent
DAC	Digital-to-Analog Converter	PMD-SAP	Physical Medium Dependent-Service Access Point
DCM	Dual Carrier Modulation	PPDU	PLCP Protocol Data Unit
EIRP	Equivalent Isotropically Radiated Power	PPM	Parts per Million
FCS	Frame Check Sequence	PRBS	Pseudo-Random Binary Sequence
FDS	Frequency-Domain Spreading	PSD	Power Spectral Density
FEC	Forward Error Correction	PSDU	PLCP Service Data Unit
FER	Frame Error Rate	PT	Preamble Type
FFI	Fixed-Frequency Interleaving	QPSK	Quadrature Phase Shift Keying
FFT	Fast Fourier Transform	RF	Radio Frequency
GF	Galois Field	RS	Reed-Solomon
HCS	Header Check Sequence	RSSI	Received Signal Strength Indicator
IDFT	Inverse Discrete Fourier Transform	RX	Receive or Receiver
IFFT	Inverse Fast Fourier Transform	SAP	Service Access Point
LSB	Least Significant Bit	SDU	Service Data Unit
MAC	Medium Access Control	SIFS	Short Interframe Spacing
MIB	Management Information Base	SME	Station Management Entity
MIFS	Minimum Interframe Spacing	TDS	Time-Domain Spreading
MLME	MAC Layer Management Entity	TF	Time-Frequency
MMDU	MAC Management Protocol Data Unit	TFC	Time-Frequency Code
MPDU	MAC Protocol Data Unit	TFI	Time-Frequency Interleaving
MSB	Most Significant Bit	TX	Transmit or Transmitter
OFDM	Orthogonal Frequency Division Modulation	UWB	Ultra Wideband
PAN	Personal Area Network	WPAN	Wireless Personal Area Network
PER	Packet Error Rate	ZPS	Zero Padded Suffix
PDU	Protocol Data Unit		
PHY	Physical (layer)		

References and Acknowledgments:

The author wishes to thank the following sources for their contributions to this document:

1. Standard ECMA -368, 1st edition – December 2005.
2. Multiband OFDM Physical Layer specifications release 1.1
3. Ultra wideband systems (Technologies and applications)
Edited by Robert Aiello and Anuj Batra

Contact Tektronix:

ASEAN / Australasia (65) 6356 3900
Austria +41 52 675 3777
Balkans, Israel, South Africa and other ISE Countries +41 52 675 3777
Belgium 07 81 60166
Brazil & South America (11) 40669400
Canada 1 (800) 661-5625
Central East Europe, Ukraine and the Baltics +41 52 675 3777
Central Europe & Greece +41 52 675 3777
Denmark +45 80 88 1401
Finland +41 52 675 3777
France +33 (0) 1 69 86 81 81
Germany +49 (221) 94 77 400
Hong Kong (852) 2585-6688
India (91) 80-22275577
Italy +39 (02) 25086 1
Japan 81 (3) 6714-3010
Luxembourg +44 (0) 1344 392400
Mexico, Central America & Caribbean 52 (55) 5424700
Middle East, Asia and North Africa +41 52 675 3777
The Netherlands 090 02 021797
Norway 800 16098
People's Republic of China 86 (10) 6235 1230
Poland +41 52 675 3777
Portugal 80 08 12370
Republic of Korea 82 (2) 6917-5000
Russia & CIS +7 (495) 7484900
South Africa +27 11 206 8360
Spain (+34) 901 988 054
Sweden 020 08 80371
Switzerland +41 52 675 3777
Taiwan 886 (2) 2722-9622
United Kingdom & Eire +44 (0) 1344 392400
USA 1 (800) 426-2200
For other areas contact Tektronix, Inc. at: 1 (503) 627-7111
Updated 12 November 2007

For Further Information

Tektronix maintains a comprehensive, constantly expanding collection of application notes, technical briefs and other resources to help engineers working on the cutting edge of technology. Please visit www.tektronix.com



Copyright © 2008, Tektronix. All rights reserved. Tektronix products are covered by U.S. and foreign patents, issued and pending. Information in this publication supersedes that in all previously published material. Specification and price change privileges reserved. TEKTRONIX and TEK are registered trademarks of Tektronix, Inc. All other trade names referenced are the service marks, trademarks or registered trademarks of their respective companies.
08/08 DM 76W-20785-1

Tektronix
Enabling Innovation



AFC Ingenieros S.A.
Paseo Imperial, 6, 2ºD
28005 Madrid
Contacto: Juan Ojeda
Directo: 91 7104883
Móvil: 629160579
Oficina: 91 3654405
Email: jojeda@afc-ingenieros.com