

Tektronix Test Solutions for a Wireless World

The Challenge of Mixed Signal Development

Market Drivers

The highly competitive commercial market is driving the need for lower development costs and faster time to market – the fact is it's expensive to be late. This need to speed development and reduce costs is driving the migration to Digital RF, where the device is defined more in digital baseband and software, allowing it to be less dependent on analog components. This development has had a profound impact on the traditional RF world, increasing the pace of innovation through greater availability of higher performance, lower power circuits that perform analog radio functions. The availability of these advanced Digital RF technologies suggests ever more ways to expand wireless communications.

Whether commercial or military, customers want more information, faster, anywhere, anytime. Digital RF technologies make wireless access available in more places, to more people, and for less money. Modern radar systems are increasingly making use of digital baseband signals, FPGA's, and digital beam-forming antenna systems known as phased arrays. The combination of advanced technical capabilities brought about by Digital RF and the increasing demand for more functionality and mobility has generated a surge of innovation in wireless communications.

Increasingly, this demand is being met by devices which are software defined, allowing for changes to be made via a simple update in firmware and a plug-in analog front end (RFIC). Communications systems such as Joint Tactical Radio (JTRS) and Project 25 (P25) are software defined radios.

With Digital RF, interfaces are in transition from analog to digital. This drives the need for more development and testing to be done in the digital baseband realm. The signals being created are increasingly complex and dynamic; there is a growing need to create signals which use complex modulation and multiplexing schemes which rapidly change frequency, amplitude, and phase.

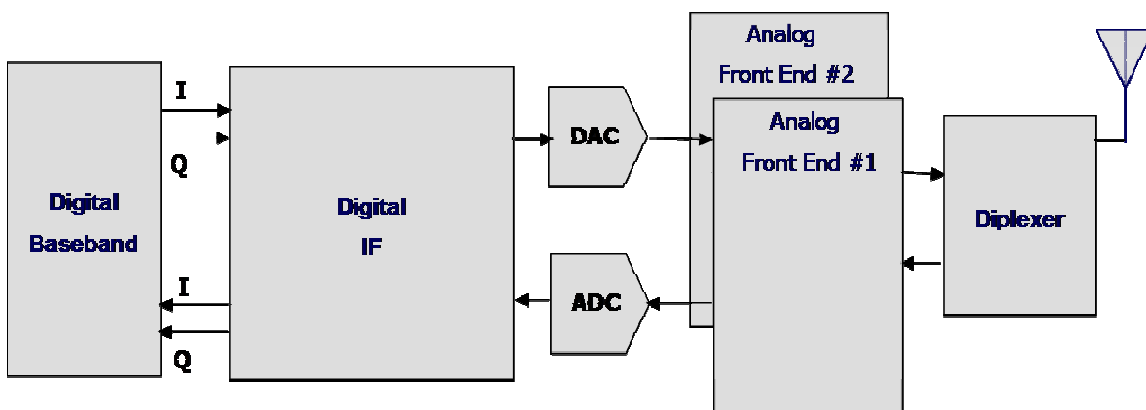

Fig 1: Block diagram of a software-defined approach where the analog front end is inter-changeable

Moving Digital and Analog Interfaces Pose Challenge for Engineers

Often ASIC designs are tested using a FPGA prototype which allows the design to be more quickly verified while running "real-speed". This approach requires a real stimulus such as an AWG5000 during the prototype phase. Then the designers need to decide on how to partition the digital and analog functionality so it can be implemented in an ASIC. The appropriate partitioning of analog and digital functionality results in faster time to market and consequently longer time-in-market. Another consideration is cost; there is the ongoing struggle to minimize the number of pins for each ASIC, thereby reducing package cost. Some designs partition so the chip interface is digital, others choose analog, some use both. Deciding which design approach to take requires mixed-signal testing using digital IQ, analog IQ, and IF signals.

Design Verification in a Mixed Signal Environment

The explosion of Digital RF has created a highly complex technology environment. More often devices are utilizing a zero-IF (direct conversion) or a low intermediate frequency (IF) approach to producing the modulated RF signal. With both of these, the traditional use of analog filters is no longer as easy or even feasible. The emphasis is now growing toward correction in baseband, utilizing active nulling of gain and DC offset mismatches as well as IQ quadrature imbalances. The AWG5000 is able to generate these digital baseband signals which can be varied both in amplitude and phase to allow for testing.

Another recent trend is the use of a Multiple Input, Multiple Output (MIMO) technique which requires numerous multibeam or adaptive-array antennas. An example of this is the 802.11n standard. Currently, most wireless systems that use this are implementing a 2x2 matrix, where two antennas are used in the transmit and receive path but work is also underway on 4x4 matrix devices. Rather than use two or more expensive Vector Signal Generators (VSGs), it is much more cost-effective to utilize an AWG5000 as this offers multiple independent channels with the ability to simulate the amplitude and phase variations found in a real-world MIMO environment without the use of electronic switching. Again, the design engineer faces the challenges found in the analog vs. digital approach. Should an RFIC be implemented to combine the signals from the antenna, or should the digital approach be implemented with a data converter for each down-converted antenna signal? Using the AWG5000 provides real-world signal simulation for testing both approaches.

Arbitrary Waveform Generators Are Part of a Complete Tektronix Digital RF Test Bench

From signal generation to acquisition, Tektronix is offering a complete Digital RF test bench. Arbitrary Waveform Generators to generate ideal, distorted or "real-world" signals. Logic Analyzers enable the capture and analysis of the digital I/Q information to more quickly debug elusive problems within the digital baseband segment of a Digital RF design. Digital oscilloscopes allow measurements of strict timing relationships including signal integrity analysis. Real-Time Spectrum Analyzers seamlessly capture RF signals changing over time and perform spectral, time, and modulation analysis with time-correlated multi-domain views.

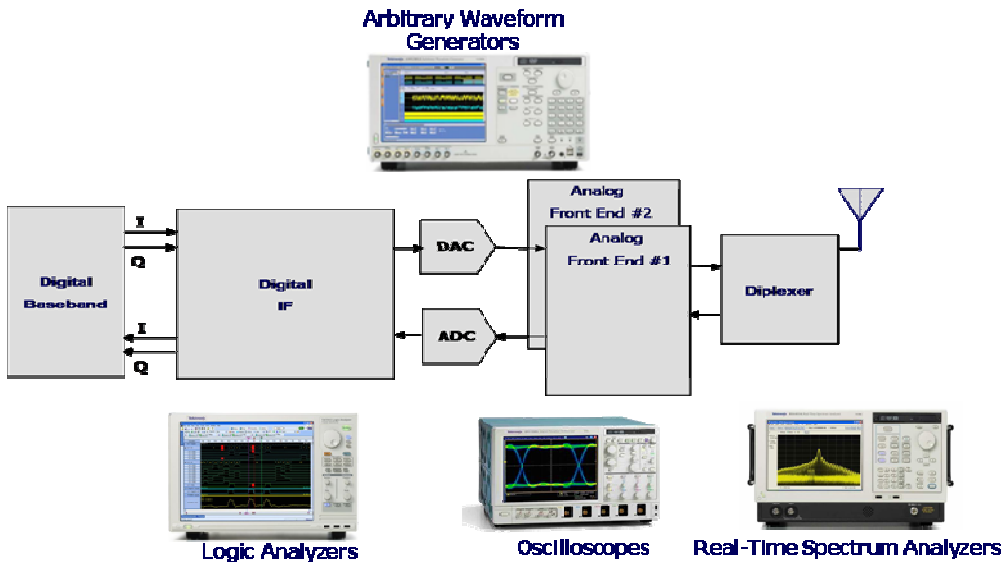

Fig 2: Test solutions for the mixed signal environment

About Tektronix

Tektronix is a leading supplier of test, measurement, and monitoring products, solutions and services for the communications, computer, and semiconductor industries - as well as military/aerospace, consumer electronics, education and a broad range of other industries worldwide. With 60 years of experience, Tektronix enables its customers to design, build, deploy, and manage next-generation global communications networks, advanced and pervasive technologies. Headquartered in Beaverton, Oregon, Tektronix has operations in 19 countries worldwide. Tektronix' Web address is www.tektronix.com.