

# Arbitrary/Function Generators provide versatile stimulus in RF Applications

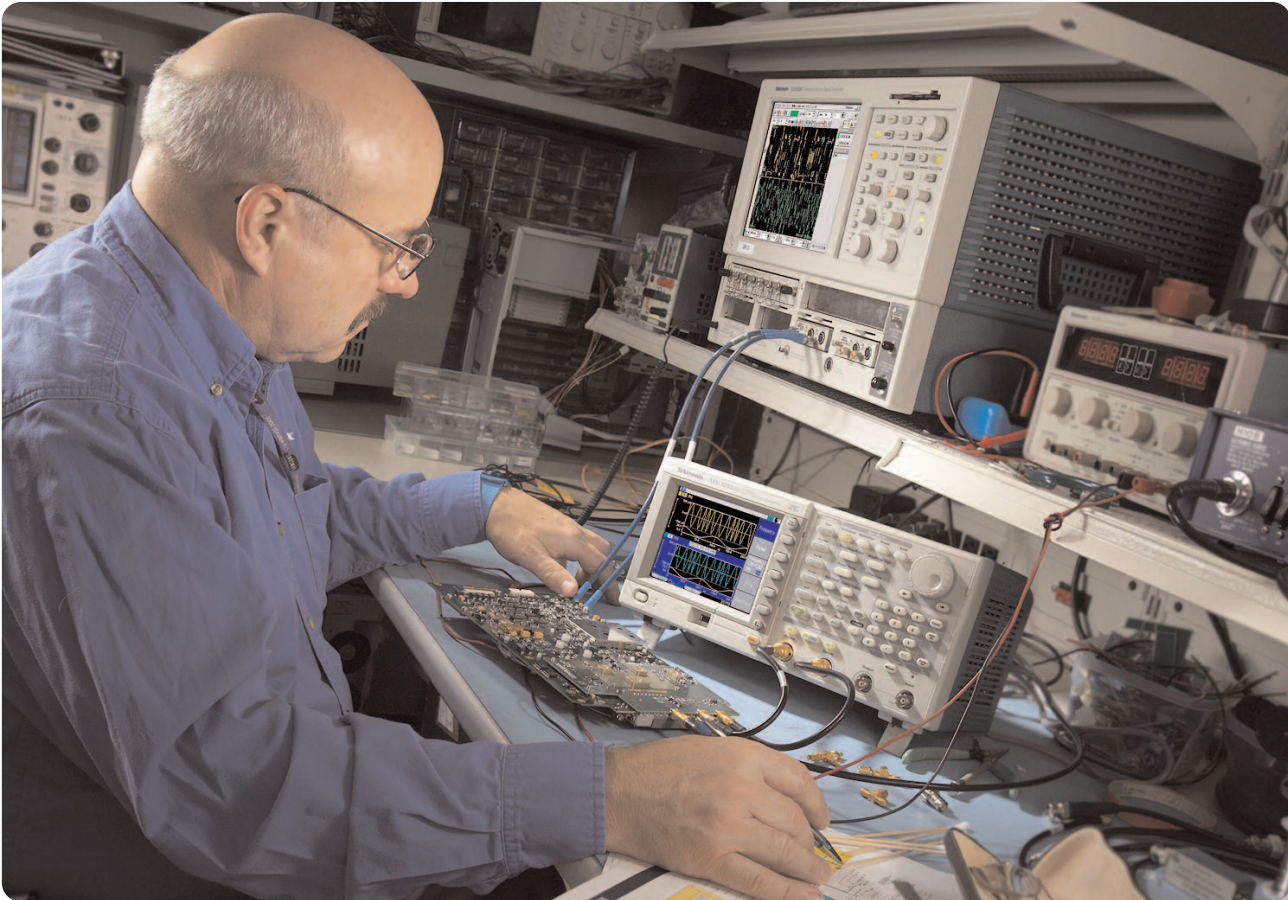

## Introduction

Testing RF components and circuits against design specifications often requires a simulated input signal to replace missing components or analyze the device characteristic under different signal conditions. For CW and modulated signals at frequencies above 100 MHz,

RF generators have been the tool of choice for many years. Recently, modern arbitrary/function generators (AFGs) have been finding increasing use in a number of RF test applications, thanks to significant improvements in versatility, flexibility and frequency range, enabled by advances in instrumentation technology.

## Arbitrary/Function Generators provide versatile stimulus in RF Applications

### ► Application Note

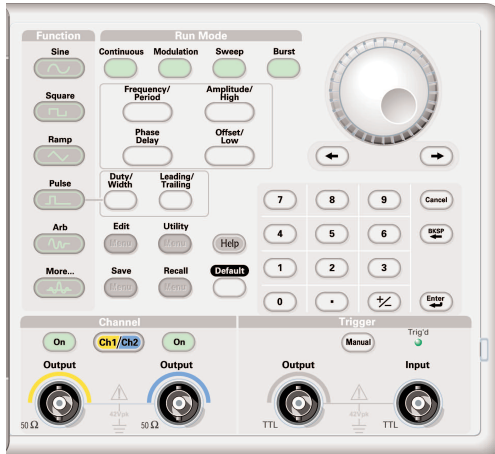

► **Figure 1.** Front panel of the AFG3000 Series.

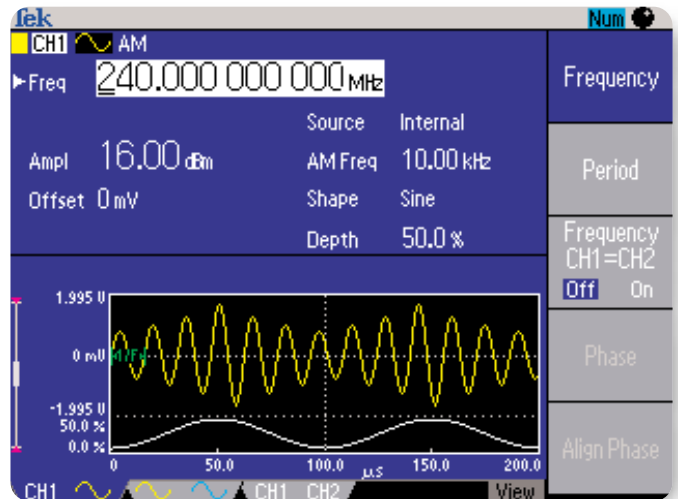

► **Figure 2.** Display of the AFG3000 Series.

Aside from CW and modulated signals, AFGs are able to generate swept sine waves and signal bursts. Multicarrier signals can be created via the arbitrary waveform function. Dual channel models even allow the generation of I/Q signals. This document described the following typical RF test applications for which AFGs are often the tool of choice:

- Measuring bandwidth of passband filters and IF amplifiers
- Measuring intermodulation distortion
- Measuring quadrature error and gain imbalance of IQ modulators
- Simulating pulsed radar signals
- Pulsed noise figure measurement

These application examples are based on the AFG3251 and AFG3252 models of the AFG300 Series of arbitrary/function generators. These instruments can generate CW signals up to 240 MHz, and pulse signals up to 120 MHz, with an output power of up to 16 dBm. The signals can be modulated in frequency, amplitude and phase via a built-in modulation generator or an external source up to modulation frequencies of 50 kHz.

## Benefits of Using Arbitrary/Function Generators in RF Applications

Users of the AFG3000 Series benefit from 25 dedicated buttons on the front panel that provide direct access to most frequently used parameters and functions. This shortens set-up and evaluation time compared to many other instruments in the category where parameters have to be accessed through layers of soft menus.

All waveform parameters are adjustable on the fly via rotary knob or numeric key pad. The amplitude can be displayed in Vpp, Vrms or dBm. During timing parameter adjustments, the output signal remains free from glitches or dropouts, which is important, for example, when characterizing devices with a frequency sweep.

A large 5.6" Color LCD displays all relevant instrument settings at a single glance along with a graphical representation of the generated waveform. This gives the operator full confidence in the instrument settings. In amplitude modulation mode, for example, the instrument not only shows the frequency and amplitude settings of the carrier, but also the modulation frequency, depth and waveform.

<b>Model</b>	AFG3251 / AFG3252
<b>Channels</b>	1 / 2
<b>Sine Wave</b>	1 $\mu$ Hz to 240 MHz
Amplitude	
$\leq$ 200 MHz	50 mV <sub>p-p</sub> to 5 V <sub>p-p</sub> / -30 dBm to 18.0 dBm
$>$ 200 MHz	50 mV <sub>p-p</sub> to 4 V <sub>p-p</sub> / -30 dBm to 16.0 dBm
Harmonic Distortion (1 V <sub>p-p</sub> )	
10 Hz to 1 MHz	$<$ -60 dBc
1 MHz to 5 MHz	$<$ -50 dBc
5 MHz to 25 MHz	$<$ -37 dBc
$>$ 25 MHz	$<$ -30 dBc
THD (10 Hz – 20 kHz, 1 V <sub>p-p</sub> )	$<$ 0.2%
Spurious (1 V <sub>p-p</sub> )	
10 Hz to 1 MHz	$<$ -50 dBc
1 MHz to 25 MHz	$<$ -47 dBc
$>$ 25 MHz	$<$ -47 dBc + 6 dBc/octave
Phase Noise, typical	$<$ -110 dBc/Hz at 20 MHz, 10 kHz offset, 1 V <sub>p-p</sub>
Residual Clock Noise	-57 dBm
<b>Modulation</b>	AM, FM, PM
Source	Internal/External
Internal Modulation Frequency	2 mHz to 50.00 kHz
<b>Frequency Shift Keying</b>	2 keys
Source	Internal/External
Internal Modulation Frequency	2 mHz to 1.000 MHz
<b>Sweep</b>	Linear, logarithmic
<b>Burst</b>	Triggered, gated
Internal Trigger Rate	1.000 ms to 500.0 s
Gate and Trigger Sources	Internal, external, remote interface
<b>Arbitrary Waveforms</b>	1 mHz to 120 MHz
Sample Rate	2 GS/s
Waveform Memory	2 to 128 K

► **Table 1.** RF related specifications of AFG3251/52.

For applications that require more than one input signal, such as RF and IF, or I and Q signals, dual channel models are available at significant cost savings over two separate single channel generators. Since the AFG3000 Series is based on Direct Digital Synthesis (DDS), signal shape and frequency can be selected completely independently in both channels. The signals

can also be locked together in frequency and/or amplitude. In this case, the phase relationship between both channels can be manually adjusted, which is extremely useful for example for measuring channel to channel timing differences in devices.

Table 1 summarizes the RF related capabilities of the AFG3251 and AFG3252.

## Arbitrary/Function Generators provide versatile stimulus in RF Applications

► Application Note

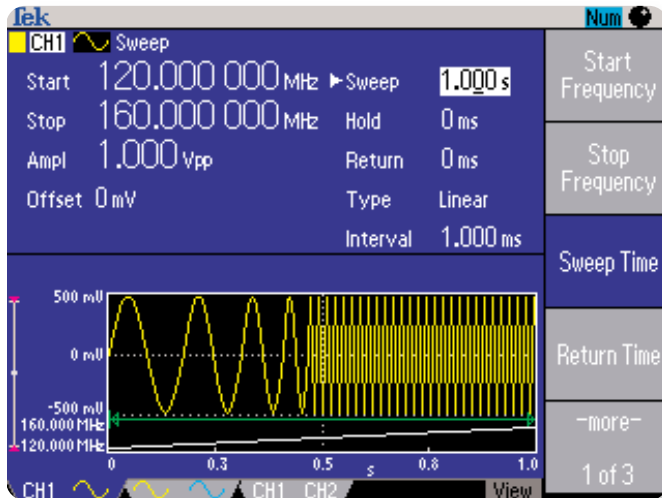

► Figure 3. AFG3000 Series display in sweep mode.

Engineers who work on different designs benefit from the versatility of AFGs. Aside from sine, pulse and arbitrary waveforms, the AFG3000 Series also excels at generating ramps, and seven other standard functions.

When using AFGs in RF test applications one needs to consider that their phase noise performance does not reach the levels provided by some dedicated RF generators, limiting their use, for example, in sensitivity testing.

### Measuring Bandwidth of Passband Filters and IF Amplifiers

Every new RF amplifier and filter design has bandpass characteristics that must be measured to ensure the product's compliance with design goals. Most amplifiers are designed to deliver a linear response over a range of frequencies appropriate to their application. Similarly, filters are designed to pass predetermined bands of frequencies and reject all others.

Both types of components tend to have a frequency range where the amplitude response is relatively "flat". At either end of this range, the amplitude response steadily decreases. The points where response is -3 dB

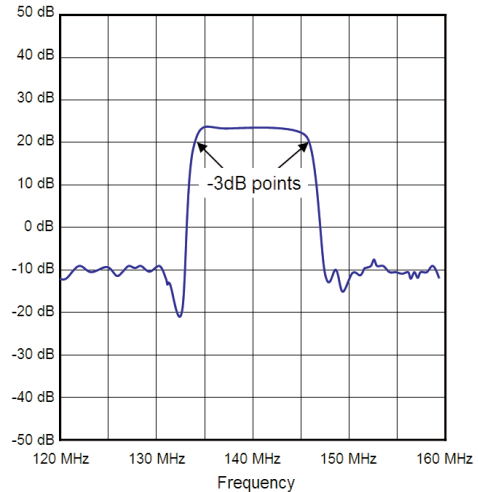

► Figure 4. Response of 140 MHz amplifier.

down from the peak-to-peak amplitude defines the bandwidth boundaries.

In this application example we will examine a 140 MHz IF amplifier and measure the lower and upper frequency where the output amplitude is -3 dB down, which is equivalent to the 70.71% of the peak-to-peak value. The AFG provides a swept sinewave as the input signal to the amplifier and a spectrum analyzer traces the signal output in peak hold mode.

Pressing the AFG's sweep mode button brings up a screen with all the essential waveform settings in view, including a representation of the waveform itself (see Figure 3). Take a close look at the waveform frame near the bottom of the screen. It summarizes all of the salient details about the generated signal: amplitude; the frequency endpoints; the slope of the "ramp" that steadily increases the frequency; and the total length (time) of the sweep.

Figure 4 depicts the measurement trace of the spectrum analyzer. Using markers, the measurement results are a frequency range of 133 MHz to 147 MHz. Outside this bandwidth, the amplifier response decays below the -3 dB point.

Parameters	Setting
Run Mode	Continuous
Function	Arb
Arb Waveform Menu	User1
Frequency	500 kHz
Amplitude	0.5 V <sub>pp</sub>

▶ **Table 2.** AFG3252 settings for IMD measurement.

In this example, the AFG's user interface and architectural advantages play a key role in getting the job done efficiently. The sweep setup procedure makes it easy to define the needed stimulus signal. The display confirms the waveform characteristics at a glance, while the numerical parameters on the same screen yield quick, precise answers about amplitude, frequency, and more.

### Measuring Intermodulation Distortion

When two or more tones interact in amplifiers, modulators or other electronic devices, they produce multiple intermodulation products. This effect is referred to as intermodulation distortion (IMD) and is caused by non-linearities of the device. In RF communication, this presents a problem as it widens the signal spectrum, interferes with the transmission signal, and reduces the dynamic range of wireless transceivers.

To measure IMD of an RF device, it needs to be stimulated with a dual tone signal and its output response measured with a spectrum analyzer. You could generate both tones separately with channels 1 and 2 of the AFG3252 and mix them externally. A more elegant approach, without the need for an external mixer, is to create the dual tone as an arbitrary waveform and generate it using only one channel of the AFG.

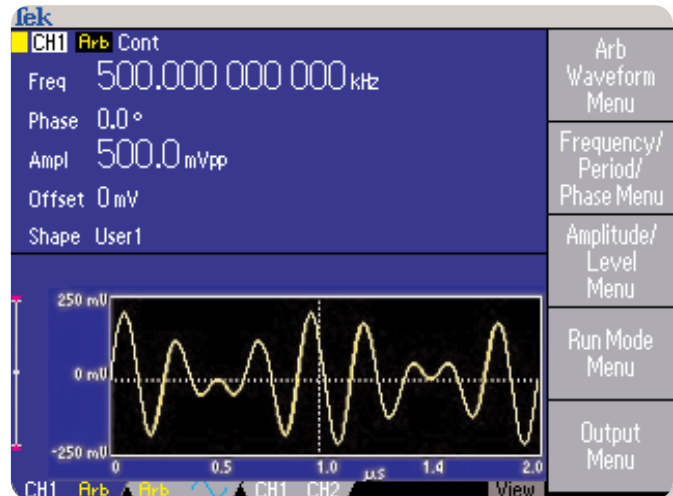

▶ **Figure 5.** AFG3252 display for dual tone waveform.

The dual tone arbitrary waveform can be defined conveniently via the waveform math function of the PC software package ArbExpress®. In this example, the AFG3252 is generating dual tones at 3.5 MHz and 4.5 MHz to test the IMD of an IQ modulator.

After the waveform files are created, they can be saved on a USB memory device for transfer to the arbitrary/function generator: Plug the USB memory with the waveform files into the front panel USB port of the AFG3252. Press the button "Edit", select "Read from..." from the screen menu, then "USB", and select the file for channel 1 from the list on the screen. Next, select "more" from the screen menu, then "Write to..." and load the arbitrary waveform into the memory User1 of the instrument. Lastly, program the AFG3252 with the settings as shown in Table 2.

## Arbitrary/Function Generators provide versatile stimulus in RF Applications

### ► Application Note

The response of the IQ modulator to the dual tone stimulus is depicted in the spectrum analyzer screenshot in Figure 6. The 3.5 MHz and 4.5 MHz dual tones are centered in the screen to the right of the local oscillator frequency. Conventional measures for quantifying device linearity are the output intercept points (OIP). These can be calculated mathematically from the power of the strongest intended tone and the suppression of the inter-modulation products relative to the power of the reference tone.

An important point to consider for IMD measurements is that the signal generator generates IMD of its own due to non-linearity in the output stage. The measured IMD at the device output is the vector sum of source and device IMD. Through a separate measurement, it was determined that the source IMD only leads to a measurement error of  $\pm 0.02$  dB for the second order IMD of the device, and  $\pm 0.13$  dB for the third-order IMD. (For more information on IMD measurements and creating dual tones with ArbExpress see application note 75W-20744-0 "Characterization of IQ Modulators Counts On Flexible Signal Generator Stimulus".)

### Measuring Quadrature Error and Gain Imbalance of IQ Modulators

IQ modulators play a critical role in modern telecommunication. Designers are concerned about amplitude imbalance and phase error between in-phase and quadrature arms of an IQ modulator, because they result in carrier feed-through and undesired sideband leakage. LO leakage is caused by minute DC offsets

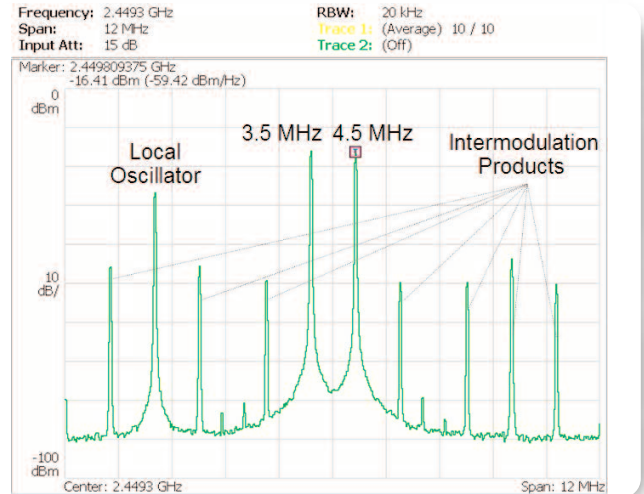

► **Figure 6.** Spectrum analyzer measurement of inter-modulation distortion.

between the differential baseband inputs and is independent of the quadrature error. The undesired sideband leakage is dependent on both amplitude imbalance and quadrature error.

To measure the amplitude imbalance and quadrature error, we can make use of the fact that the sideband suppression can be optimized by adjusting phase and amplitude offsets between I and Q channel. When only one parameter is adjusted, sideband suppression asymptotically approaches a limit. Therefore, gain and phase need to be adjusted consecutively in several steps until the undesired sideband leakage is minimized. The opposite values of the Q channel adjustments then reflect the mismatch inherent to the modulator.

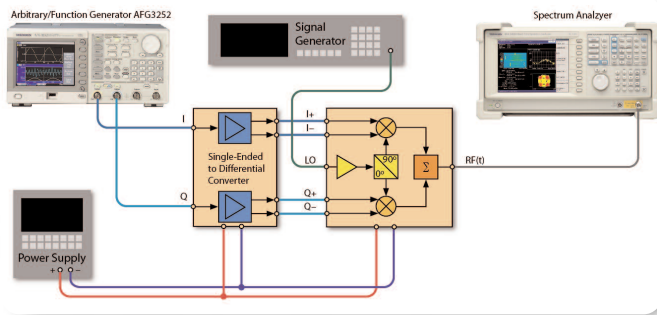

▶ **Figure 7.** Measurement setup for IQ modulator characterization.

The measurement setup is shown in Figure 7. The arbitrary/function generator provides the signal input to the IQ modulator. Initially, it is configured as for the bandwidth measurements (Table 3).

To determine the DC offsets of the differential baseband inputs, adjust the DC bias on the single-ended to differential converter circuit until the IQ modulator output power at the LO frequency is minimized.

To determine the IQ modulator's gain and phase errors, observe the undesired sideband power on the spectrum analyzer while holding amplitude and phase of the AFG3252's channel 1 (I signal) constant and making iterative adjustments to the amplitude and phase of channel 2 (Q signal) until the sideband power level is minimized. Unlike vector signal generators with built-in IQ generators that require reloading of the signal vector for parametric adjustments, the AFG3252 allows direct adjustment of phase and amplitude via the rotary knob on the front panel, with an amplitude resolution of 0.1 mV and a phase resolution of 0.01 degrees.

Parameters	Setting
Channels 1 / 2 - Run Mode	Continuous
Channels 1 / 2 - Function	Sine
Frequency: Frequency CH1=CH2	On
Amplitude: Level CH1=CH2	On
Amplitude	0.5 V <sub>pp</sub>
Frequency	1 MHz
Channel 2: Phase	90°

▶ **Table 3.** AFG3252 settings for IQ modulator characterization.

As it turns out, the sideband on the IQ modulator, used as an example here, could be suppressed by reducing the amplitude in channel 2 from 500 mV to 461.8 mV and the phase from 90° to 89.79°. Accordingly, the IQ amplitude imbalance is 0.0764 or 0.35 dB and the quadrature error 0.21°.

### Simulating Pulse Radar Signals

Engineers tasked with the development of radar systems frequently need to simulate radar signals. To determine the distance of a target object, pulse radar sends out short and powerful pulse trains and measures the time it takes for the signal to reach the target and return to the antenna. Since the transmitter antenna is rotating, the target is only exposed to the radar pulse for a short period. A common requirement is to simulate a burst of pulses for this time during which the antenna has line-of-sight alignment with the target.

## Arbitrary/Function Generators provide versatile stimulus in RF Applications

### ► Application Note

Parameters	Setting
Function	Pulse
Frequency	1 kHz
Amplitude – High Level	5.000 V
Amplitude – Low Level	0 mV
Width	5%
Run Mode	Burst
N-Cycles	1000
Trigger Interval	4 s

► **Table 4.** AFG3252 settings for IQ modulator characterization.

Arbitrary/function generators like the AFG3251/52 are ideally suited to generate low frequency radar with pulse frequencies up to 120 MHz (lower VHF band). Typical applications include naval and long distance surveillance, and advanced alert for anti-ballistic missiles. To generate pulse bursts, the instrument is configured as a pulse generator in burst mode. Many radar applications benefit from the instruments' sharp rise and fall time of 2.5 ns. Depending on the application, the instruments can also be triggered internally or via an external signal.

Some radar applications also require non-square pulse shapes to maximize target detection. To meet these requirements, the desired pulse shapes can be created via equations or other means with ArbExpress waveform editing software and generated with the AFG's arbitrary waveform function.

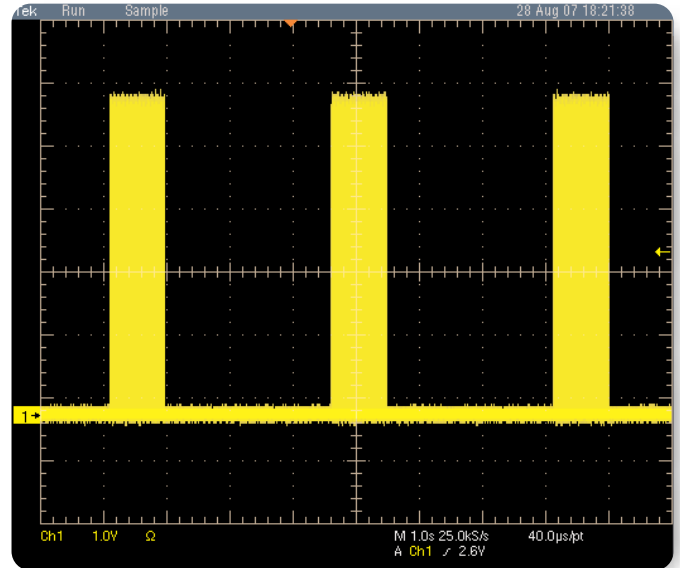

► **Figure 8.** Oscilloscope screen with pulsed radar signal.

As an example, Table 4 shows the settings to simulate pulse radar bursts with 1000 pulses with a repetition frequency of 1 kHz and a duty cycle of 5% that repeat every four (4) seconds. Figure 8 shows the output signal of the AFG3251/52 as measured with an oscilloscope.

The AFG3251/52 have the advantages that waveform parameters can be accessed directly via shortcut keys and modified on the fly without having to stop the output signal. The instruments also support pulse duty cycles as low as 0.001% which is often a requirement in radar applications.

### Pulsed Noise Figure Measurement

Noise figure is an important parameter of telecommunication amplifiers as it specifies how much noise the amplifier contributes to the noise in the output signal. It describes the degradation of the signal to noise ratio caused by the components in the signal chain. It is defined as the ratio of the signal to noise ratio at the output to that at the input:

$$NF = \frac{SNR_{input}}{SNR_{output}}$$

Cellular hand-set and base station amplifiers for TDMA, GSM and other burst-type radio standards are only powered during the active time slots to conserve power. To obtain accurate measurement results, the noise figure must be measured with the amplifier operated in pulse mode as during normal operation.

One popular method of measuring noise figure is the Y Factor method. It relies on a calibrated noise source with known excess noise ratio (ENR) that is connected to the input of the amplifier under test (see Figure 9). Channel 1 of the AFG3252 turns the amplifier on and off via a pulse signal that drives the amplifier bias input. Pulse width and repetition rate are set according to the standard to be tested. The spectrum analyzer is configured in time gated mode to measure the amplifier output only during the switch-on phase. Channel 2 of the AFG generates the trigger signal to the spectrum that is synchronous to the pulse driving the amplifier bias. To derive the noise figure with this method we first need to determine the so called Y factor which is the ratio of output noise densities from the noise source in its ON and OFF states. To obtain reproducible measurement results sufficient averaging of the measurements is required.

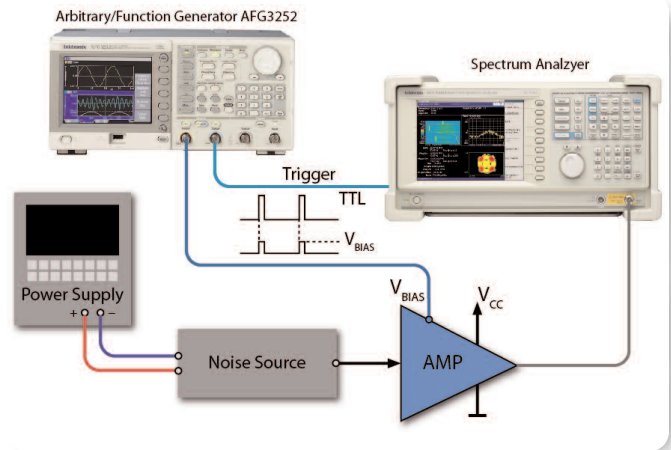

▶ **Figure 9.** Test setup for pulsed noise figure measurement.

With the measured Y factor and the ENR provided by the noise source manufacturer for the frequency of interest, the noise figure can now be calculated as follows:

$$NF = ENR_{dB} - (10 \log(Y-1))$$

As an example, let us assume that ENR is 5.28 dB and that the measured noise density increased from -90 dBm/Hz to -87 dBm/Hz after the noise source was turned on. This yields a Y factor of 3 dB which then needs to be converted to a linear value for use in the above equation. Using the formula  $Y(\text{lin}) = 10^{Y(\text{dB})/10}$ , we obtain  $Y(\text{lin}) = 1.995$ . Plugging this value into the above formula for the noise figure yields  $NF = 5.3$  dB.

The advantage of using the AFG3000 in this application is that it offers two channels that can be synchronized in frequency and have independently adjustable amplitude to match the required bias level at the amplifier and the trigger input of the spectrum analyzer or noise figure meter.

## Arbitrary/Function Generators provide versatile stimulus in RF Applications

► Application Note

### Summary

Modern arbitrary/function generators are versatile, flexible and affordable tools that support numerous RF test applications. The AFG3000 Series can generate two independent or tightly synchronized RF, IF and IQ signals up to 240 MHz. Custom waveforms can be generated via the arbitrary waveform function.

The AFG3000 Series helps users save setup time because the more important parameters can be selected on the AFG3000 Series via designated buttons much faster than the layered menus of alternative

instruments. A large screen that shows all relevant settings and a graphical wave shape representation gives the user full confidence in their instrument settings.

All waveform parameters including the phase between channels 1 and 2 can be adjusted on the fly while the test keeps running. This shortens evaluation time significantly compared to other solutions that require reloading of the waveform for parameter changes.

Despite all their benefits, arbitrary/function generators have limitations over dedicated RF generators, especially where frequencies higher than 240 MHz or low phase noise are a requirement.



## Contact Tektronix:

**ASEAN / Australasia** (65) 6356 3900

**Austria** +41 52 675 3777

**Balkan, Israel, South Africa and other ISE Countries** +41 52 675 3777

**Belgium** 07 81 60166

**Brazil & South America** (11) 40669400

**Canada** 1 (800) 661-5625

**Central East Europe, Ukraine and the Baltics** +41 52 675 3777

**Central Europe & Greece** +41 52 675 3777

**Denmark** +45 80 88 1401

**Finland** +41 52 675 3777

**France** +33 (0) 1 69 86 81 81

**Germany** +49 (221) 94 77 400

**Hong Kong** (852) 2585-6688

**India** (91) 80-22275577

**Italy** +39 (02) 25086 1

**Japan** 81 (3) 6714-3010

**Luxembourg** +44 (0) 1344 392400

**Mexico, Central America & Caribbean** 52 (55) 5424700

**Middle East, Asia and North Africa** +41 52 675 3777

**The Netherlands** 090 02 021797

**Norway** 800 16098

**People's Republic of China** 86 (10) 6235 1230

**Poland** +41 52 675 3777

**Portugal** 80 08 12370

**Republic of Korea** 82 (2) 6917-5000

**Russia & CIS** +7 (495) 7484900

**South Africa** +27 11 206 8360

**Spain** (+34) 901 988 054

**Sweden** 020 08 80371

**Switzerland** +41 52 675 3777

**Taiwan** 886 (2) 2722-9622

**United Kingdom & Eire** +44 (0) 1344 392400

**USA** 1 (800) 426-2200

For other areas contact Tektronix, Inc. at: 1 (503) 627-7111

Updated 1 June 2007

Our most up-to-date product information is available at: [www.tektronix.com](http://www.tektronix.com)



Copyright © 2007, Tektronix. All rights reserved. Tektronix products are covered by U.S. and foreign patents, issued and pending. Information in this publication supersedes that in all previously published material. Specification and price change privileges reserved. TEKTRONIX and TEK are registered trademarks of Tektronix, Inc. All other trade names referenced are the service marks, trademarks or registered trademarks of their respective companies.

9/07 FLG/WOW

75W-21197-0

# Tektronix

Enabling Innovation



AFC Ingenieros S.A.  
Paseo Imperial, 6, 2ºD  
28005 Madrid

Contacto: Juan Ojeda  
Directo: 91 7104883  
Móvil: 629160579  
Oficina: 91 3654405

Email: [jojeda@afc-ingenieros.com](mailto:jojeda@afc-ingenieros.com)